



Steca Power Tarom

2070, 2140, 4055, 4110, 4140

Specially designed for industrial and outdoor applications, the Steca Power Tarom comes with an IP 65 casing made of powder-coated steel.

This solar charge controller can be used to control system sizes of up to 8400 Wp at three voltage levels (12 V, 24 V, 48 V). The Steca Power Tarom is based on the technology of the Steca Tarom controller. When connected in parallel, several controllers from this series can be operated via a standard DC bus in a simple solar home system or a hybrid system. This allows an output of over 20 kWp to be reached.

Product features

- Hybrid controller
- State of charge determination with Steca AtonIC (SOC)
- Automatic detection of voltage
- PWM control
- Multistage charging technology
- Load disconnection depending on SOC
- Automatic load reconnection
- Temperature compensation
- Common positive grounding or negative grounding on one terminal
- Integrated data logger
- Night light function with Steca PA 15
- Integrated self test
- Monthly maintenance charge
- Integrated energy meter

Electronic protection functions

- Overcharge protection
- Deep discharge protection
- Reverse polarity protection of load, module and battery
- Reverse polarity protection by internal fuse
- Automatic electronic fuse
- Short circuit protection of load and module
- Overvoltage protection at module input
- Open circuit protection without battery
- Reverse current protection at night
- Overtemperature and overload protection
- Battery overvoltage shutdown

Displays

- Text LCD display
— for operating parameters, fault messages, self test

Operation

- Simple menu-driven operation
- Programming by buttons
- Manual load switch

Interfaces

- RJ45 interface

Options

- External temperature sensor
- Alarm contact

Certificates

- Approved by the World Bank for Nepal
- Fit for use in tropical areas (DIN IEC 68 part 2-30)
- Compliant with European Standards (CE)
- Made in Germany
- Developed in Germany
- Manufactured according to ISO 9001 and ISO 14001

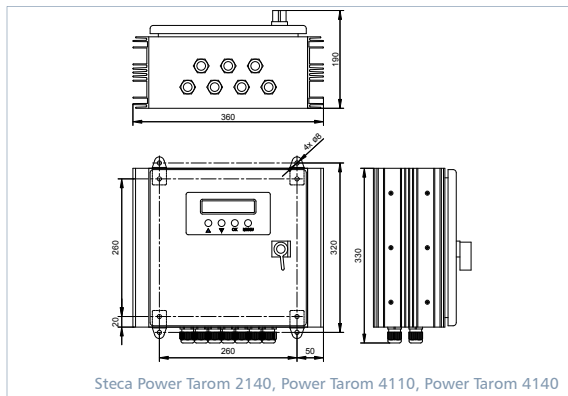

	2070	2140	4055	4110	4140
Characterisation of the operating performance					
System voltage	12 V (24 V)		48 V		
Own consumption	14 mA				
DC input side					
Open circuit voltage solar module	< 50 V		< 100 V		
Module current	70 A	140 A	55 A	110 A	140 A
DC output side					
Load current	70 A	70 A	55 A	55 A	70 A
programmable	End of charge voltage	13.7 V (27.4 V)		54.8 V	
	Boost charge voltage	14.4 V (28.8 V)		57.6 V	
	Equalisation charge	14.7 V (29.4 V)		58.8 V	
	Reconnection voltage (SOC / LVR)	> 50 % / 12.6 V (25.2 V)		> 50 % / 50.4 V	
	Deep discharge protection (SOC / LVD)	< 30 % / 11.1 V (22.2 V)		< 30 % / 44.4 V	
Operating conditions					
Ambient temperature	-10 °C ... +60 °C				
Fitting and construction					
Terminal (fine / single wire)	50 mm ² - AWG 1	95 mm ² - AWG 000	50 mm ² - AWG 1	70 mm ² - AWG 00	95 mm ² - AWG 000
Degree of protection	IP 65				
Dimensions (X x Y x Z)	330 x 330 x 190 mm	360 x 330 x 190 mm	330 x 330 x 190 mm	360 x 330 x 190 mm	
Weight	10 kg				

Technical data at 25 °C / 77 °F



Steca PA Tarcom Data logger



Steca PA HS200 Shunt



Steca PA 15 Remote control

[areas of application]

