



## Steca PR 2020 IP

### IP 65 version

The functionality of the Steca PR 2020 IP is based on the Steca PR line of solar charge controllers.

This is equipped with a large display which shows the current state of charge (SOC) as a percentage and graphically in the form of a tank. The key component of the charge controller is the state of charge determination, which has been significantly improved. The auto-adaptive state of charge algorithm results in optimal battery maintenance and control over the module output of up to 480 Wp which can be connected to it. The Steca PR 2020 IP has been specially designed for operation in difficult environments with high salt, moisture and dust content.



### Product features

- Hybrid controller
- State of charge determination with Steca AtonIC (SOC)
- Automatic detection of voltage
- PWM control
- Multistage charging technology
- Load disconnection depending on SOC
- Automatic load reconnection
- Temperature compensation
- Common positive grounding or negative grounding on one terminal
- Integrated data logger
- Night light function
- Integrated self test
- Monthly maintenance charge
- Integrated energy meter

### Electronic protection functions

- Overcharge protection
- Deep discharge protection
- Reverse polarity protection of load, module and battery
- Automatic electronic fuse
- Short circuit protection of load and module
- Overvoltage protection at module input
- Open circuit protection without battery
- Reverse current protection at night
- Overtemperature and overload protection
- Battery overvoltage shutdown

### Displays

- Graphical LCD display
  - for operating parameters, fault messages, self test

### Operation

- Programming by buttons
- Manual load switch

### Options

- External temperature sensor
- Alarm contact

### Certificates

- Fit for use in tropical areas (DIN IEC 68 part 2-30)
- Compliant with European Standards (CE)
- RoHS compliant
- Made in Germany
- Developed in Germany
- Manufactured according to ISO 9001 and ISO 14001

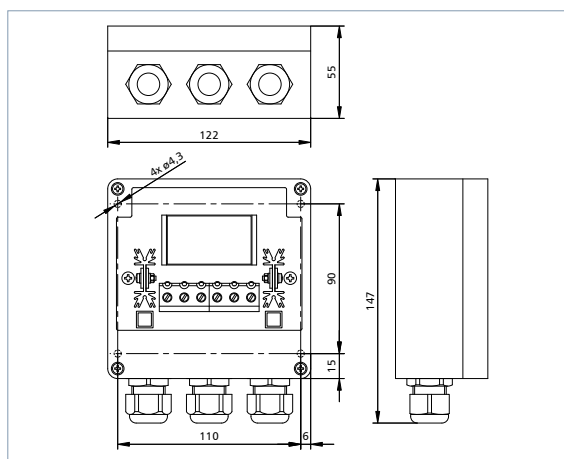

	PR 2020-IP
<b>Characterisation of the operating performance</b>	
System voltage	12 V (24 V)
Own consumption	12 mA
<b>DC input side</b>	
Open circuit voltage solar module	< 47 V
Module current	20 A
<b>DC output side</b>	
Load current	20 A
End of charge voltage	liquid 13.9 V (27.8 V); gel 14.1 V (28.2 V)
Boost charge voltage	14.4 V (28.8 V)
Equalisation charge	14.7 V (29.4 V)
Reconnection voltage (SOC / LVR)	> 50 % / 12.6 V (25.2 V)
Deep discharge protection (SOC / LVD)	< 30 % / 11.1 V (22.2 V)
<b>Operating conditions</b>	
Ambient temperature	-10 °C ... +50 °C
<b>Fitting and construction</b>	
Terminal (fine / single wire)	16 mm <sup>2</sup> / 25 mm <sup>2</sup> - AWG 6 / 4
Degree of protection	IP 65
Dimensions (X x Y x Z)	122 x 147 x 55 mm
Weight	350 g

Technical data at 25 °C / 77 °F

[areas of application]

