



Steca Solarix MPPT

MPPT 2010

Steca Solarix MPPT 2010 is a solar charge controller with Maximum Power Point Tracking. It is specially designed to work with all established module technologies and is optimized for solar systems with module voltages higher than the battery voltage. The Steca Solarix MPPT 2010 is especially qualified in combination with grid tied solar modules. The advanced MPP-tracking algorithm from Steca assures that the maximum available power of the solar generator is charged to the batteries. The Steca Solarix MPPT 2010 with latest technology ensures full performance in all conditions, a professional battery care combined with modern design and excellent protection.



Product features

- Maximum Power Point Tracker (MPP tracker)
- Voltage and current regulation
- PWM control
- Current compensated load disconnection
- Automatic load reconnection
- Temperature compensation
- Monthly maintenance charge

Electronic protection functions

- Overcharge protection
- Deep discharge protection
- Reverse polarity protection of load, module and battery
- Reverse polarity protection by internal fuse
- Automatic electronic fuse
- Short circuit protection
- Overvoltage protection at module input
- Open circuit protection without battery
- Reverse current protection at night
- Overtemperature and overload protection
- Battery overvoltage shutdown

Displays

- Multifunction LED display
- Multi-coloured LED
- 5 LEDs show operating states
 - for operation, state of charge, fault messages

Options

- Night light function pre-set in the factory or adjustable via Steca PA RC 100
- Parameterisation of function values via Steca PA RC 100
- External temperature sensor

Certificates

- Compliant with European Standards (CE)
- RoHS compliant
- Made in Germany
- Developed in Germany
- Manufactured according to ISO 9001 and ISO 14001



Steca PA TS10
External temperature sensor



Steca PA RC100
Remote control

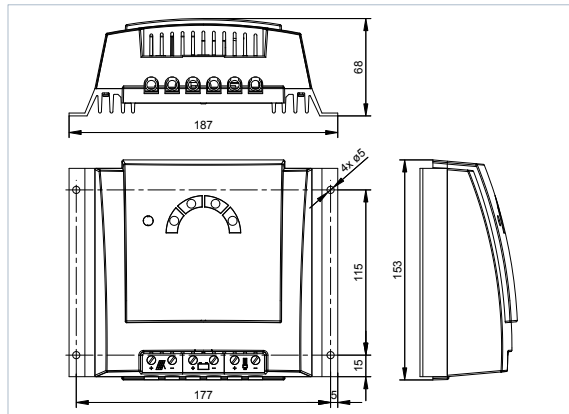

	MPPT
Characterisation of the operating performance	
System voltage	12 V (24 V)
Nominal power	250 W (500 W)
Max. efficiency	> 98 %
Own consumption	10 mA
DC input side	
MPP voltage	15 V (30 V) < V _{module} << 100 V
Open circuit voltage solar module ** (at minimum operating temperature)	17 V ... 100 V (34 V ... 100 V)
Module current	18 A
DC output side	
Charge current	20 A
Load current	10 A
End of charge voltage*	13.9 V (27.8 V)
Boost charge voltage*	14.4 V (28.8 V)
Equalisation charge*	14.7 V (29.4 V)
Reconnection voltage* (LVR)	12.5 V (25 V)
Deep discharge protection* (LVD)	11.5 V (23 V)
Operating conditions	
Ambient temperature	-25 °C ... +40 °C
Fitting and construction	
Terminal (fine / single wire)	16 mm ² / 25 mm ² - AWG 6 / 4
Degree of protection	IP 32
Dimensions (X x Y x Z)	187 x 153 x 68 mm
Weight	approx. 900 g

* see options

Technical data at 25 °C / 77 °F

****CAUTION:** If an open circuit voltage of more than 100 V is supplied to the connected solar module, the controller will be destroyed. When selecting the solar module, it is important to bear in mind that the open circuit voltage should never exceed 100 V over the entire working temperature range. When using solar modules with a maximum open circuit voltage of between 75 and 100 V (over the entire temperature range), all installation steps must be carried in accordance with protection class II.

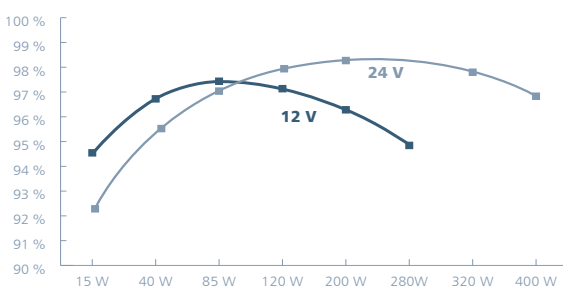

[areas of application]

